

**trotec**  
laser. marking cutting engraving



# **SP Series**

**Laser Cutting Systems  
Leading Large Format**

# ***Leading Large Format***

The SP series laser cutters are our complete solution for processing large format materials. Whether for display production and shop fitting, architectural model making, membrane keyboard production, print service providers, advertising technology, finishing of advertising or technical textiles and furniture construction, our laser systems are developed for 24/7 operation and let you work quickly, productively and reliably.

No matter whether crystal-clear edges without post-processing or finest details and radii in acrylic, sealed cut edges without fraying in textiles or the chip-free processing of various plastics, wood or wood composites - you will increase your productivity simply by reducing process steps such as flame polishing, material clamping or seaming. By additionally saving set-up costs, cleaning time and tool procurement, you still have time and money to accept new orders and drive your company growth.



As a technology leader with a worldwide sales network, Trotec develops and produces first-class laser systems to make our customers more profitable. This also applies to the SP series laser cutters for fast and precise processing of large format materials. Four-sided access, loading and unloading during material processing, Tandem Assistant, highest cutting performance on the entire processing area and integration into your data workflow thanks to RIP and CAD compatibility make our SP series the leader in large format.

The product line is 100% developed and manufactured in Austria, sold in over 18 sales companies and makes customers in over 90 countries more profitable. We advise and accompany our customers: The Trotec Academy offers training courses on materials and technology and continuously trains the service and sales teams. Exhaust systems, laser and engraving material as well as service products complete the product portfolio.



# **One Solution For Many Industries**



## ***Added value of printed materials through the use of laser cutting machines***

Print service providers who use laser cutters stand out from the competition by implementing creative design ideas and new brand design concepts. With this universally applicable tool, the most filigree designs can be created from a wide variety of materials such as plastic or wood. Whether high-quality outdoor signage or displays for indoor use, the contour cut of printed high-quality materials such as acrylic creates added value for advertising technicians or printers. Time savings due to elimination of work steps and set-up times, no tool wear, etc. - these are just a few of the many advantages offered by the SP series laser cutters.

## ***The advantages of a laser for acrylic processing for display and shop fitters***

Compared to processing acrylic with alternative technologies such as a milling machine, laser cutting is up to 88% more economical. Due to the crystal-clear edges after cutting acrylic with the laser, flame polishing is no longer necessary and the finest details and radii are possible. Extraordinary shapes for displays make a finished product more interesting and of higher quality. Display manufacturers who offer contour cutting of printed materials as a service can generate additional sales and stand out from the mass of suppliers. It gains the productivity and the high quality of the laser-cut edge.

Due to their (material) flexibility, excellent cutting quality and high efficiency, machines of the SP series are used successfully in many different industries.



***Sealed cut edges without post-processing for digitally printed textiles in advertising technology***

The large format processing of printed advertising textiles such as banners and beach flags, both indoors and outdoors, is becoming increasingly important in the advertising industry. The challenges of mechanical textile finishing such as fraying, tool wear or distortion can be avoided with laser technology. The cut edges are sealed directly by the laser beam by contactless cut & seal, which prevents fraying and eliminates time-consuming re-seaming of the textiles. Due to the accuracy of fit of the laser, no overcut is necessary and there is no need for regrinding or frequent blade changes.



***Plastics processing made easy - best material utilization through precise cuts***

Laser cutting of technical plastics such as foils and sheet materials offers a number of advantages. The wear-free process leads to constant cutting results, with the contact-free tool even sensitive materials such as thinnest foils can be processed without distortion or tearing. The small cutting gap allows tight nesting, increases material utilization and allows you to produce more end products from less raw material. In addition, compared to conventional cutting technologies, fast and precise cutting results are possible - both in terms of contour accuracy, especially for the finest details, and cutting depth for kiss-cut applications.

# Endless Application Possibilities

The SP series are CO<sub>2</sub> laser cutting machines for large format materials. As highly efficient flatbed systems, they convince in the most demanding cutting applications with the most diverse materials.

From acrylic and paper to plastic and wood to textiles and many other materials, the flexibility of our laser cutters makes you flexible in your possibilities.



Production of point of purchase displays with highest precision



Print & cut displays with unusual shapes



Large-format engravings for wall panels

© subildot



Exterior signage



Interior signage laser cut and engraved



Acrylic illuminated letters

© foliendesign.de

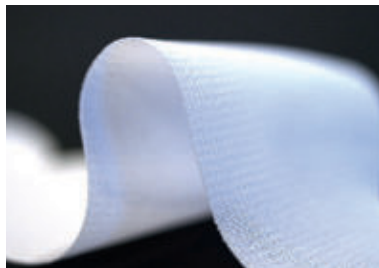

Textile cutting with sealed edges



Finishing of technical components



Finest details are possible without post-processing



Crystal clear cut edges up to 25 mm acrylic



Cutting of technical textiles



© Junkers & Müllers GmbH

Cut polyester cover for light boxes

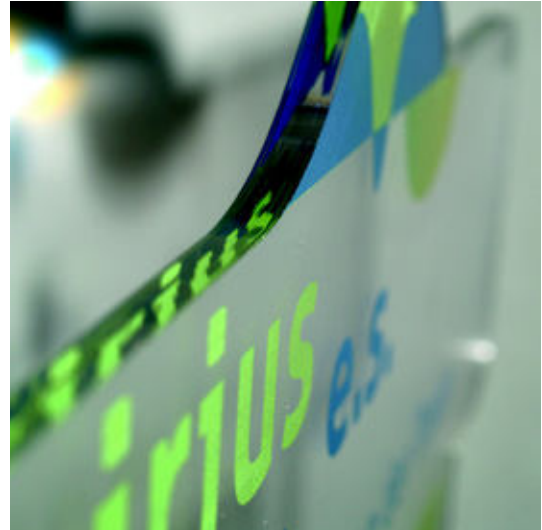

Print & cut of acrylic

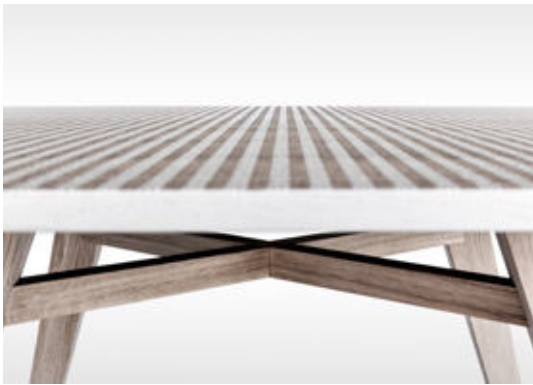

© sublidot

Filigree patterns on surfaces or furniture



© Boyd & Ogier

Detailed architectural models made of a wide variety of materials



© Berger Textiles

Finishing of large advertising textiles



© Zoran Dobric

Individual laser cutting for sample production

# ***Impressive Material Diversity***

With the SP series of laser machines, you can cut or engrave the widest possible range of materials. The palette ranges from acrylic, plastic or wood, cardboard, MDF, textiles and foils. Discover the possibilities.





	<b>Cutting</b>	<b>Engraving</b>
<b>Plastics</b>		
Acrylic (PMMA)	●	●
Acrylonitrile butadiene styrene copolymer (ABS)	●	●
Rubber (laser rubber)	●	●
Polyamide (PA)	●	●
Polybutylterephthalat (PBT)	●	●
Polycarbonate (PC)	●	●
Polyethylene (PE)	●	●
Polyester (PES)	●	●
Polyethylene terephthalate (PET)	●	●
Polyimide (PI)	●	●
Polyoxymethylene (POM) e.g. Delrin®	●	●
Polypropylene (PP)	●	●
Polyphenylene sulfide (PPS)	●	●
Polystyrene (PS)	●	●
Polyurethane (PUR) foam	●	●
Foam (PVC free)	●	●
PETG (modified PET)	●	
SAN	●	
<b>Textiles</b>		
Polyester (PES)	●	
Felt	●	●
Velvet	●	●
Microfiber	●	
Nylon	●	
Spacer fabrics	●	
Leather	●	●
Artificial leather	●	●
natural fiber (e.g. cotton, linnen)	●	●
Wool	●	
Silk	●	
Aramide	●	
<b>Miscellaneous</b>		
Wood	●	●
Cardboard	●	●
Paper white	●	●
Paper coloured	●	●
Food	●	●
Glass		●
Stone		●
Cork	●	●
Ceramics		●
Mirror		●

### **Materials you should not process with a laser**

Please note that certain types of material should not be engraved or cut with a laser because of their chemical make-up. These materials contain dangerous substances that are released during processing in the form of gases and dust, jeopardizing both the user and the functioning of the machine. Some of these materials include:

- Inferior leather (Chrome VI)
- Carbon fibers (carbon)
- Polyvinyl chlorides (PVC) including PVC based synthetic leather
- Polyvinyl butyral (PVB)
- Polytetrafluorethylenes (PTFE /Teflon®)
- Beryllias
- Materials containing halogens (e.g. fluorine, chlorine, bromine, iodine and astatine), epoxy or phenolic resins

**Important:** Be wary of materials specified as "flame retardant". This property is achieved through bromine, which is then released during processing.

# Leading Large Format



**SP2000**



**SP1500**



**SP500**



**SP3000**

## Optimized Working Area

All platforms are optimized for standardized material sizes. Save time and money on cutting, use more standard blanks per table, and use the entire work area.



**SP4000**

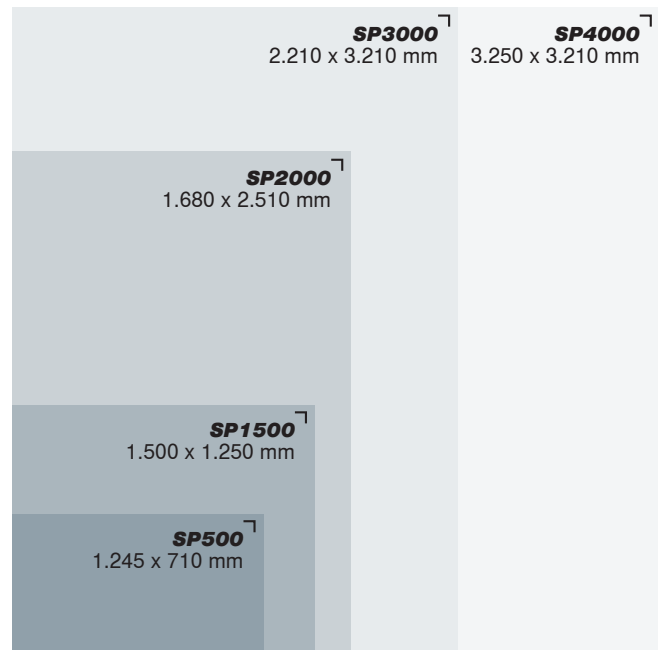

### **Highest level of productivity and user friendliness**

Trotec CO<sub>2</sub> laser cutters are designed for fast and precise processing of large format materials. Highest laser cutting speed, the four-sides access and Tandem Assist ensure maximum productivity. Use the entire work area, with no downtime. Due to high RIP and CAD compatibility the seamless integration of the laser cutter into your workflow is possible.



### **Highest level of cutting quality with every application**

Trotec developed a unique, multifunctional table concept for the SP series laser cutting machines. The ideal table for every application can be selected and replaced easily and quickly. Additional functions for outstanding cutting quality include an exhaust system located directly at the work head, a sectioned exhaust system at the processing table, as well as the option of digital regulation of the compressed air.

### **Reliable, low maintenance operation**

The movement system, the drive design, the electronics and the processing head, as well as the CeramiCore® laser source provide the highest quality and offer the best performance. With Trotec InPack Technology™, all sensitive laser cutting system components, such as lenses, mirrors or motors, are protected against dust.

The Trotec safety concept ensures optimum protection of the operator during the operation of the laser class 2 device, while the customized service packages guarantee 24/7 operation.



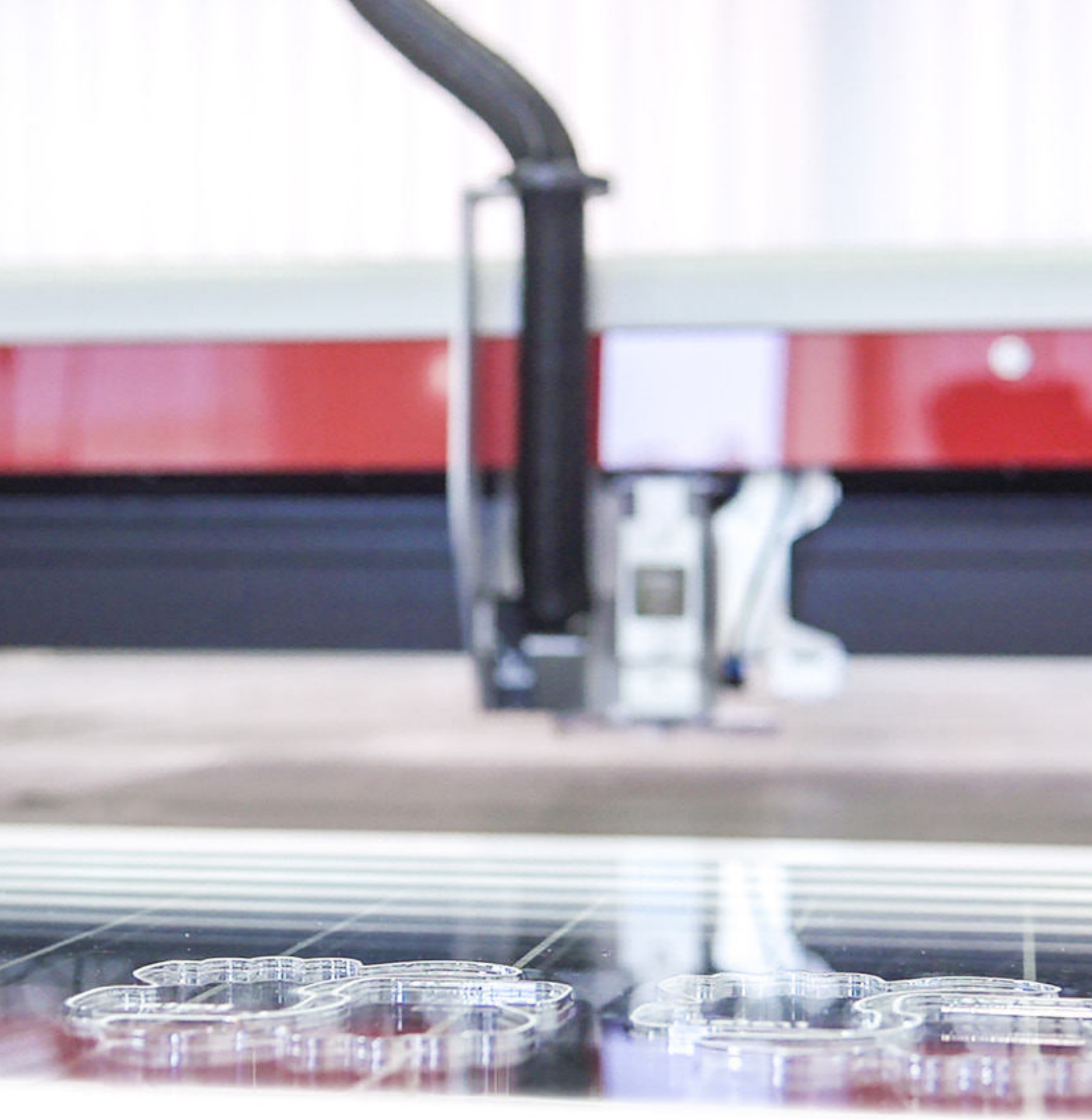

***Highest Level Of  
Productivity And User  
Friendliness***

### **Four sides access**

The working area of the SP3000 and SP2000 laser cutter is designed for large-format materials and high-volume production, and can be easily accessed from all four sides. This allows fast and ergonomic loading and unloading, even during processing.

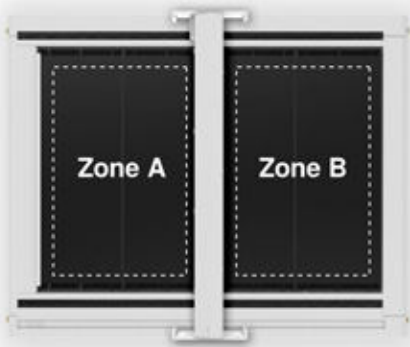

### **Non-stop laser cutting with the Tandem Assist**

The Tandem Assist provides efficient and error-free support to the operator in his workflow. With this JobControl® laser software function, the work area can be virtually split into two zones. While the laser cutter in zone A is processing the material, the finished parts can be removed in zone B and the work area can be reloaded. This minimizes idle times and significantly increases productivity.

### **Workflow Integration**

RIP and CAD compatibility make it possible to seamlessly integrate a Trotec laser cutter into your workflow. Thanks to the fully automated PDF and DXF interface Trotec UniDrive, data can be sent to the laser cutter from the prepress, or work can be prepared via monitored folders, called "Hot Folders." Time-intensive preparation or parametrization of the cutting data is not required.

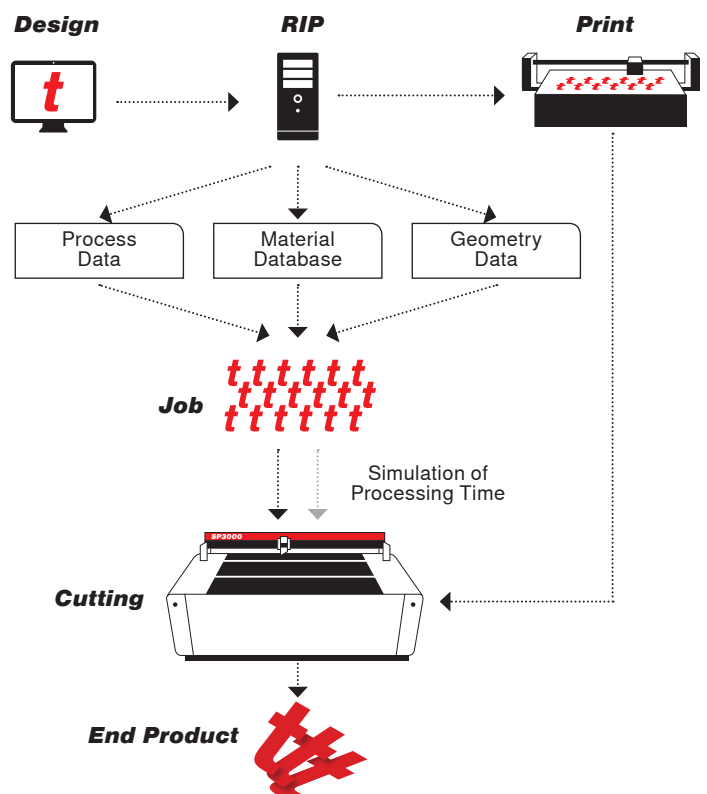

# ***Leading Large Format SP series laser cutter***

The laser cutting machines of the SP series are CO<sub>2</sub> laser machines for large format materials. The highly efficient laser plotters (flatbed lasers) are ideal for demanding cutting applications, e.g. of plastic or acrylic, textiles, wood and other materials. The SP laser cutting machines from Trotec are 100% developed and produced in Austria.

Customer benefit is our top priority when developing new products. Intelligent design makes a decisive contribution here: faster operability and increased ergonomics create more efficient workflows and thus profitability for our customers. Despite their open design, they meet the requirements of laser class 2 and are therefore absolutely safe.





**GERMAN  
DESIGN  
AWARD  
SPECIAL  
2017**



# ***Highest Level Of Productivity And User Friendliness***

***JobControl® laser software***

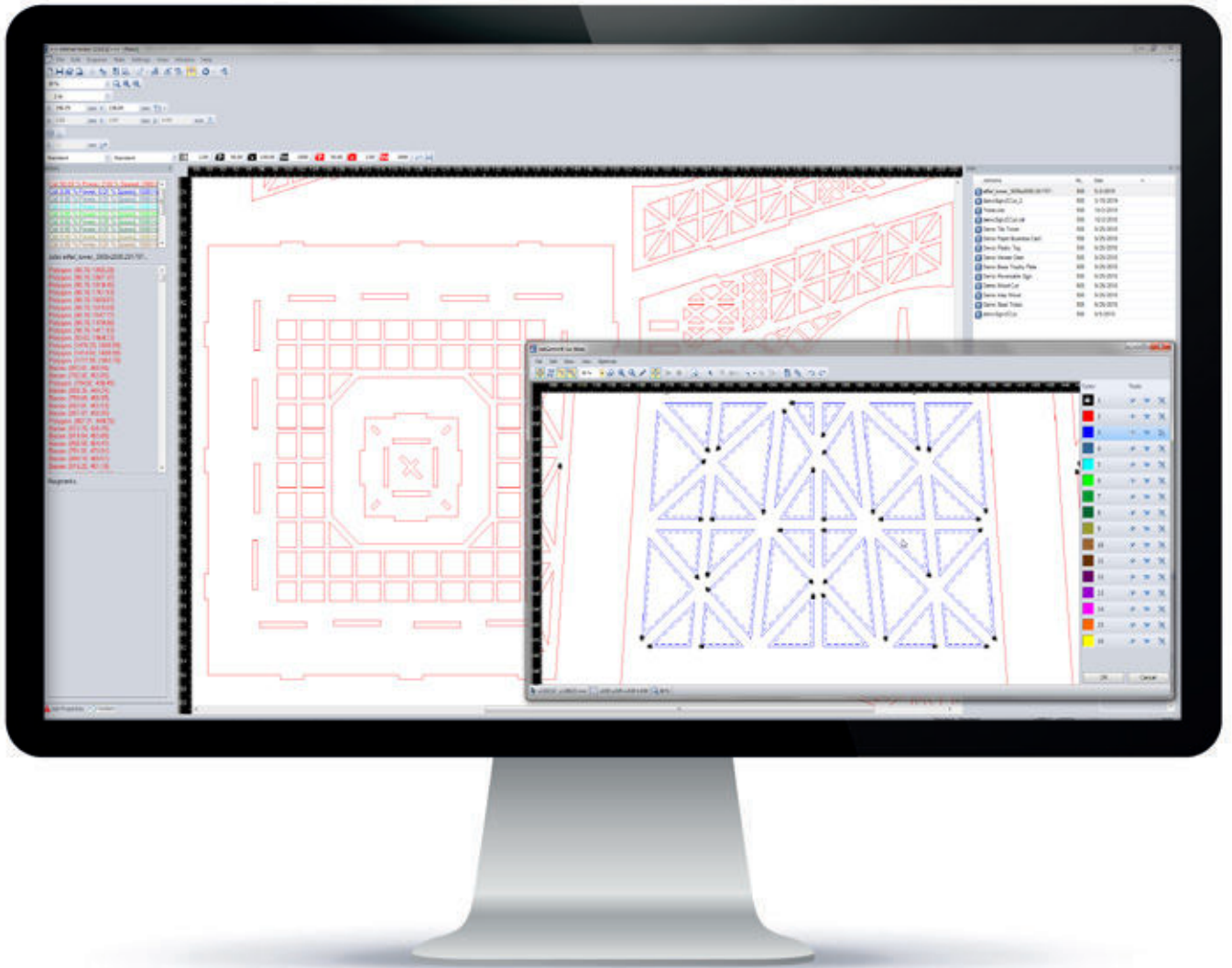

***Simply intuitive. Work efficiently.***

Our JobControl® software program was developed to be easy to use and highly efficient. It includes multiple performance-related features and intuitive user friendliness. Whether you are a beginner or an experienced user, Trotec JobControl® facilitates your daily work with the laser and supports you with perfect results.



## ***As easy as printing***

JobControl® software is a tool that allows every user to immediately control all laser functions thanks to its extremely easy operation. Our laser software allows fast and efficient working in familiar graphics or Windows® program environment, for example with Adobe Illustrator®, Adobe Photoshop®, AutoCAD®, InkScape®, Corel Draw®, etc.

Similar to printing, the user simply sends the finished graphics to the laser via the special Trotec printer driver. At the touch of a button, the machine begins to engrave or cut the inserted material with the stored settings, and you are done!

You prefer automated workflows? No problem, because our UniDrive option allows the use of hot folders for the automatic transfer of PDFs or DXF files to the laser.

## ***As productive as you are***

In addition to straightforward usability, JobControl® offers a variety of intelligent features that make your success even more likely. For example, bi-directional communication, the JobTime Calculator, markers, vector sorting, job preview and a number of others:

- The material database provides parameters for over 50 different materials to choose from. Any new materials can be added quickly and easily.
- Process types stored in the printer driver simplify everyday work by automatically optimizing graphically required processes.
- In addition, JobControl® can be further customized and adapted to your needs with advanced settings.

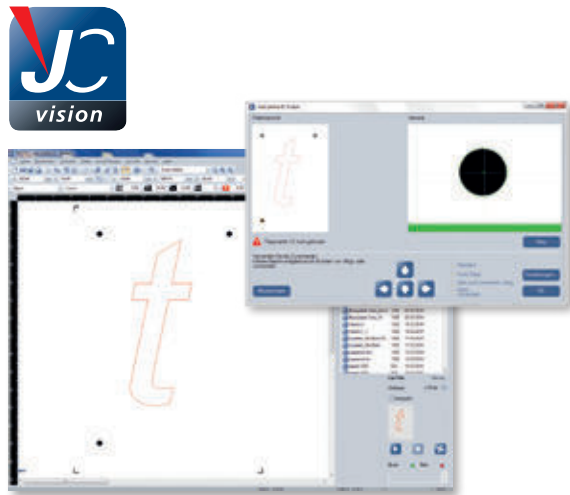

## ***JobControl® Vision***

### ***Precise laser cutting of printed materials***

Create amazing details and meet tightest tolerances with Trotec JobControl® Vision. The Vision module uses registration marks to determine the position and rotation of printed sheet material on the working area of the laser. The system detects print distortions and adjusts the cutting path dynamically to match the artwork. No matter if flexible or rigid materials. This speeds up your production and costly miscuts can be avoided. This guarantees a perfectly cut end product.

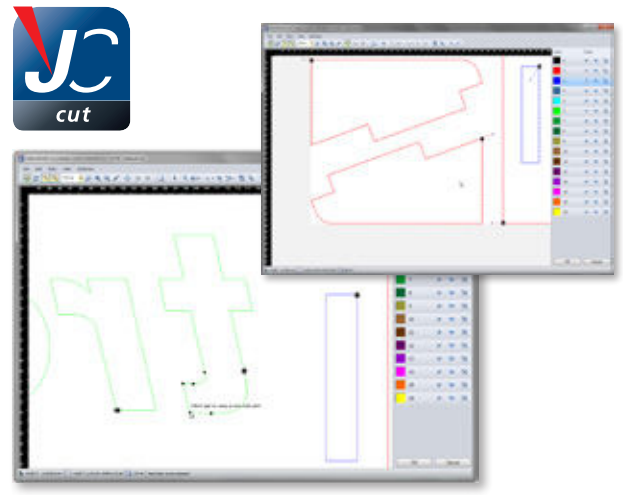

## ***JobControl® Cut***

### ***JobControl® integrated optimization of basic cutting jobs***

JobControl® Cut is a tailor-made, fully integrated solution in our Trotec laser software. It enables you to easily process and optimize cutting geometries without changing the original geometries in the graphical software again. Only in a few steps color orders are changed, cutting gaps automatically filled, start points defined, the fitting accuracy of components secured, lead-ins and lead-outs defined as well as the processing time optimized. All for a perfect cutting result.

# Highest Level Of Cutting Quality

Due to the multifunctional table concept, quick adaptation to different requirements is one of the numerous highlights of the SP series. You can therefore count on first-class cutting results with variable thicknesses and sizes of your workpieces.



## **Slat cutting table**

The cutting table with aluminum slats is mainly used for cutting thicker materials (from 6 mm thickness) and for parts wider than 100 mm. Acrylics can be cut with no reflections by exchanging the aluminum with acrylic slats. One can reduce the number of supporting points by removing slats individually, depending on the job.

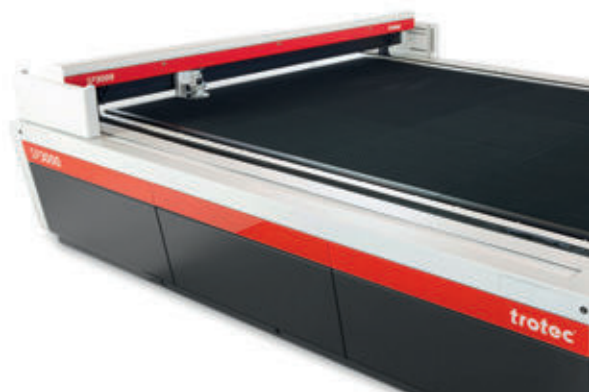

## **Aluminum cutting grid table**

This robust, universal cutting table is characterized by an extremely stable grid and a long lifetime. It is particularly suitable for cutting tasks with parts smaller than 100 mm, as these remain in a flat position after the cut. Compared to the slat cutting table the aluminum cutting grid table has more supporting points.



## **Acrylic cutting grid tabletop**

The universal cutting tabletop is ideal for the reflection-free cutting of thin acrylics with a thickness up to 8 mm. Like with the aluminum cutting grid table parts smaller than 100 mm remain in a flat position after the cut.

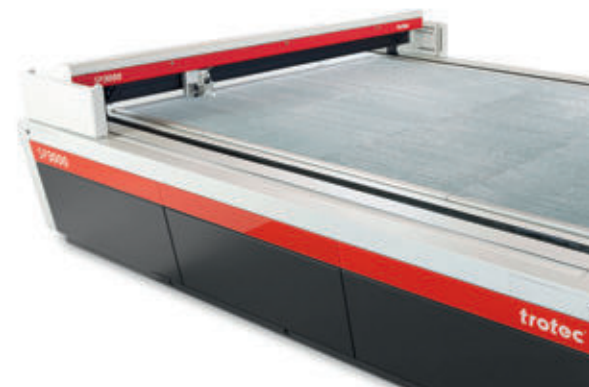

## **Honeycomb cutting table**

This processing table is especially suitable for applications that require minimal back reflections and optimum flatness of the material, like for example cutting films.



### **Digital table exhaust**

With the SP3000 and SP2000 laser cutters, it is possible to activate the exhaust system only in specific zones of the work area. Thanks to the segmented

exhaust system, the work area can be divided into four zones with the SP3000 and two zones with the SP2000. The segments can be individually activated by pressing a button on the operating console.



### **Conveyor belt with feeder unit and unloading table**

The SP4000 is a fully automated laser system dedicated for soft signage applications such as banners, flags or light boxes. By combining an automated solution with high cutting speeds and convincing accuracy, high production volumes

with perfect quality are achieved. The large format laser can be flexibly configured around a conveyor belt with feeder unit and unloading table – depending on the desired workflow. All components are perfectly matched.

***Reliable, Low Maintenance  
Operation***

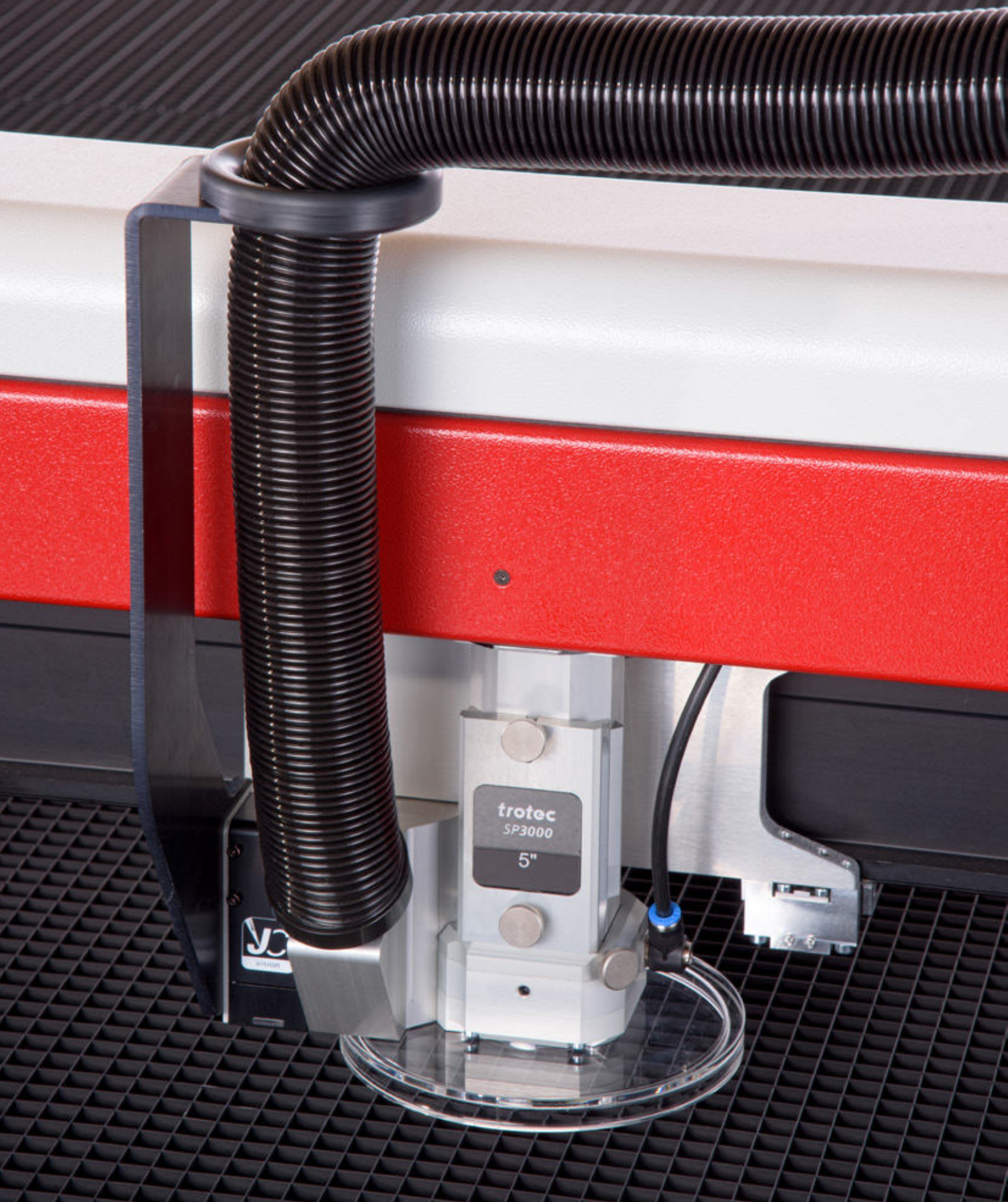



### **Trotec safety system**

During the development of the SP3000 and SP2000 laser cutting machines, Trotec engineers paid special attention to mechanical safety in addition to laser safety. The SP3000 and SP2000 laser cutters comply with all relevant standards, guaranteeing safe operation.

### **Laser class 2 for 24/7 production**

The systems of the SP series are certified as laser class 2. The laser beam path is completely encapsulated, and exits the working head equipped with an active laser deflector shield.

Therefore, no structural measures with laser protection walls or special laser safety training for your staff are necessary.

### **Dust protection with InPack Technology™**

With InPack Technology™, we were the first manufacturer in the world to design a self-contained axes design and put it into practice. It perfectly protects both lens and mirrors, electronics, motors and axes from dust and other disruptive factors. The advantages:

- Ensures trouble-free work over an extremely long period of time
- Exceptionally low maintenance and cleaning costs, thus low operating costs even with very intensive use
- Even higher productivity



### **The entry into large format**

The closed machine concept of the SP500 and SP1500 offers ideal conditions for perfect cutting of materials in standard plate sizes that tend to generate high dust levels. This, as well as high-quality and perfectly matched components, low maintenance costs and an intelligent selection of options make both machines the most profitable laser cutting and engraving machines in their class.

## ***Free access while the machine is cutting***

Maximum operator protection is a priority at Trotec. A moving light curtain system and safety bumpers mounted onto the moving x-axes define a protection zone. As soon as the operator enters this protection zone, the machine is stopped immediately. This makes free access to the working area possible while the machine is cutting.

This means real safety for your staff, with access to the complete working area at all times. A special highlight: If the protection zone is tripped and processing thus interrupted, the resume function allows seamless continuation of the processing later.



## ***100% Ceramic***

Trotec laser systems are equipped with laser sources from the American OEM manufacturer Iradion. The patented CeramiCore® laser source technology impresses with its reliability, engraving quality and longevity. Highlights: The resonator of the laser source, i.e. the point at which the laser radiation is generated, is 100 percent ceramic. Ceramics lasers can be operated at much higher pressure, resulting in better and faster pulsability, which in turn is crucial for high speed engraving and marking. Laser users will therefore benefit from the highest engraving quality.



## ***Your safety in pre-purchase***

This ranges from simple sampling, in which we solve typical tasks with our machines, to complex preliminary studies, in which we work with you to develop an overall concept for integrating the laser into your production environment. We examine application aspects (such as the development of the right setup for the specific requirements of your application or precise cycle time studies).

Of course, we also ask questions about the workflow, the material to be processed or the associated processing files. We want to create a solid basis for your investment decision and offer you maximum security. Together with you, we work out the right solution for your application in advance.

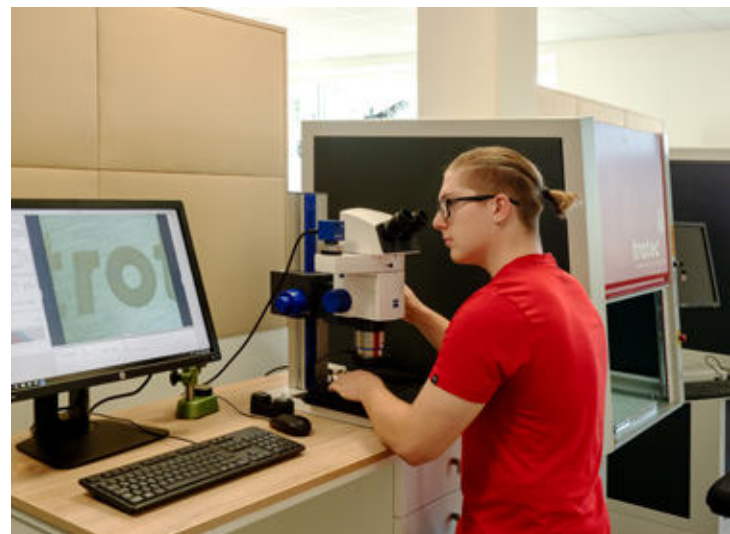

## **Better environments with Atmos exhaust systems**



With the Atmos model series, Trotec is also setting new standards with regard to exhaust systems. As the only laser manufacturer, we produce models that are optimally adapted to the respective laser machine. A suitable exhaust system ensures the safe and clean operation of your laser machine. It reliably removes dust and gases from the processing area and, with its activated carbon filters, it filters out odors that may be generated during laser processing. The Atmos exhaust system helps to deliver the best possible cutting and engraving quality.

### **Clean**

The efficient and thorough filtration of dust, gas and odors extends the service life of your laser system and guarantees a clean and healthy working environment for every user.

### **Intelligent**

For many years, Trotec has been working on optimal coordination of laser and extraction systems. The result is a host of intelligent features. For example, operation via membrane keyboard, the FlowControl Technology, a control function via the laser software and the Trotec iOS app.

### **Economical**

A good extraction solution improves the engraving and cutting results. Low maintenance costs are guaranteed thanks to sophisticated filter solutions. Due to the bi-directional laser communication, the extraction is only activated when it is necessary. Thus, the laser optics are optimally protected and the filter service life maximized. Your advantage: Thanks to Trotec Service from a single source, the Atmos exhaust system is maintained together with your laser.

### **Atmos Duo Plus**

Stand-alone dual turbine design for double performance in demanding applications with medium to high dust generation. The plus of double activated carbon also makes it suitable for odour-intensive applications.

### **Atmos Pre-Filter**

If very large quantities of dust are to be filtered, the use of a pre-filter system is recommended. This is installed between the laser unit and the extraction system. With the help of cleanable cartridges, the filters of the actual extraction system are optimally protected, whereby the filter service life can be increased many times over. Atmos pre-separators are available in 3 different versions:

- with manual cleaning
- with automatic cleaning
- with automatic cleaning and additive dosing

### **PowerJet**

This high performance exhaust system has been developed especially for laser dust to provide an economic and efficient separation system. The "All in One" - concept represents the perfect solution for challenging application areas. Dust filtration - odor reduction - turbine - combined into one device for a safe laser operation and a clean environment!

# **Trotec Laser & Engraving Materials**

***Top materials online***



With the launch of our extensive line of laser and engraving materials, Trotec has introduced a game changing concept: a single source for low-cost, high quality materials, industry-leading laser equipment, and technical applications support from experts with a knowledge of the systems you are using and the materials you are processing. Our comprehensive line of laser and engraving materials includes laserable wood panels (including MDF and plywood), acrylic sheets in more than 100 colors and surfaces, a broad range of laminates (including multi-layer engraving materials for laser or milling), laserable paper, and more. In addition to the convenience of a single-source solution, using our materials and products provides a number of benefits.

***Benefits include:***

- Lowest cost on premium products
- Enhanced design for improved results
- In-house technical support
- Fast delivery
- Easy online purchasing

Trotec materials are tested to determine laser parameters, then the parameters are stored in JobControl® laser software settings. This allows you to spare yourself from the costly and time-consuming testing of the optimal settings.

## ***Welcome to our web shop***

You can quickly and easily purchase our high-quality laser and engraving materials in our web shop at

***[www.trotec-materials.com](http://www.trotec-materials.com)***

In our web shop you will find a comprehensive assortment of products, up-to-date information about our materials, usage and processing tips, and practical sample instructions.



# **Trotec**

## **Worldwide!**

Trotec is a world leader in laser technology headquartered in Austria, and part of Trodat-Trotec Holding. With innovative concepts and products, we have succeeded again and again in setting new standards ever since the company was founded in 1997. Whether in terms of quality, new developments, or service, we get the same result: enthusiastic and successful customers around the world.

Trotec's consistent commitment to customer support is the reason for the company's global success, as well as one of the central drivers of motivation and innovation globally. At Trotec, supporting our customers is not just an abstract value but practiced reality.

Trotec has direct subsidiaries in 18 countries and 68 demo rooms for laser product demonstrations. Overall, with 113 distribution partners we serve customers in over 90 countries.

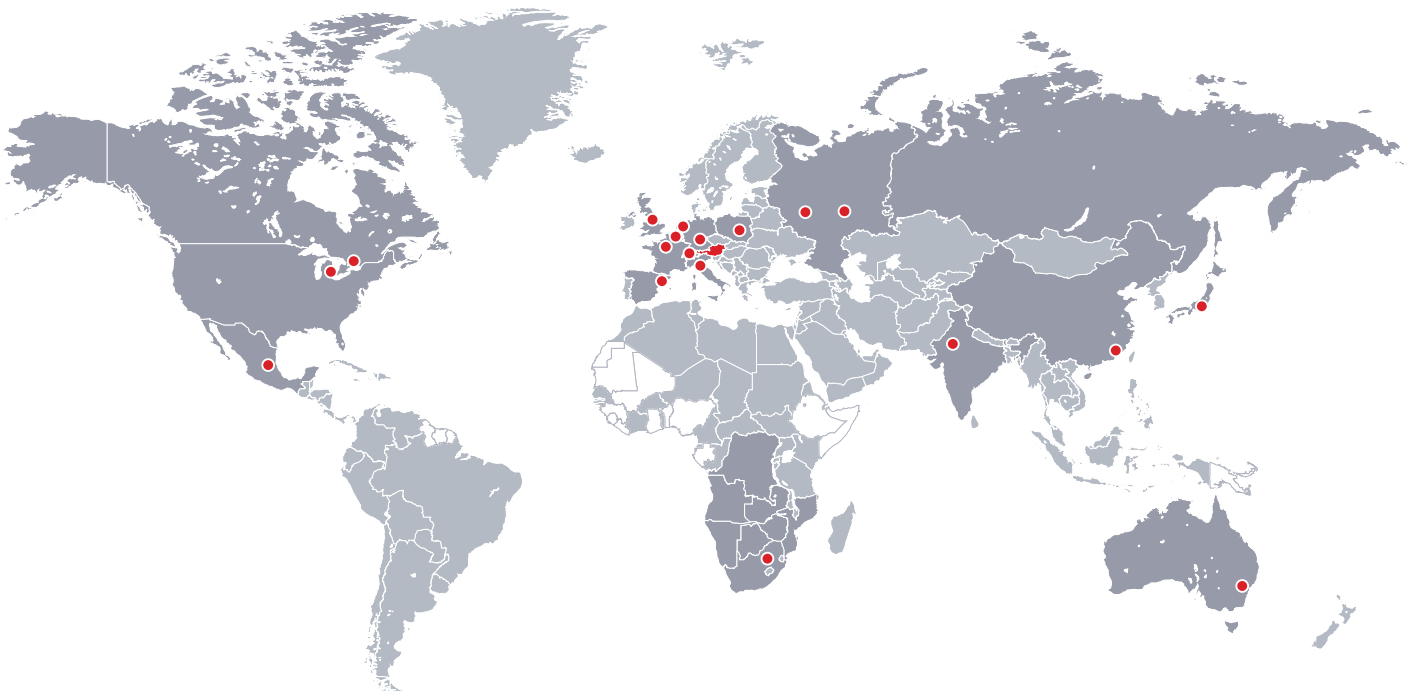

# SP Portfolio Overview

This overview of the SP portfolio should assist you in identifying the differences between the individual laser systems. You can find exact technical details in the data sheets for the respective products.



	SP4000	SP3000
Working area (W x D mm)	3250 x 3210	2210 x 3210
Height <sup>1</sup> of workpiece (mm)	50	50
Loading area (W x D mm)	3500 x ∞	2500 x ∞
Overall dimensions (W x D x H mm)	4112 x 4346 x 1230	3078 x 3914 x 1230
Max. processing speed	n/a	1 m/sec.
Max. acceleration	1g	1g
Technology motion system	Brushless DC servo motors	Brushless DC servo motors
Laser power CO <sub>2</sub>	60-400 watts	60-400 watts
Laser class	2 <sup>4</sup>	2
Weight <sup>2</sup>	2100 kg	1600 kg
Power consumption	400V 3 Ph. / 50/60 Hz / 3x16 A	400V 3 Ph. / 50/60 Hz / 3x16 A
<b>Software</b>		
JobControl®	●	●
JobControl® Vision	○	○
JobControl® Cut	○	○
<b>Functions and Options</b>		
Four sides access		●
Tandem assist		○
Digital table exhaust	○	○
Feeder unit	○	
Unloading table	○	
Pass-through		
Air-flushed optics	●	●
Travelling exhaust	○	○
Gas kit	●	●
Rotary attachment		
InPack Technology™	●	●
Harsh environment protection kit	●	●
OptiMotion™	●	●
Sonar Technology™	○	○
TroCare	○	○
2 years warranty	●	●
<b>Multifunctional table concept</b>		
Aluminum cutting grid table		○
Acrylic cutting grid table or tabletop		○
Aluminum slat cutting table		○
Acrylic slat cutting table		○
Vacuum table		
Honeycomb cutting table		○
Wire mesh conveyor belt	●	
<b>Lenses</b>		
2,0 inch CO <sub>2</sub>		
2,5 inch CO <sub>2</sub>	●	●
2,5 inch CO <sub>2</sub> clearance lens		
3,75 inch CO <sub>2</sub>		
5,0 inch CO <sub>2</sub>	○	○
<b>Compatible exhaust systems</b>		
	Vent Set 3000 Atmos PowerJet	Vent Set 3000 Atmos PowerJet

● Standard

○ Optional

1 Based on standard lens

2 Depending on laser power

3 Laser class 4 with pass-through

4 With optional safety kit



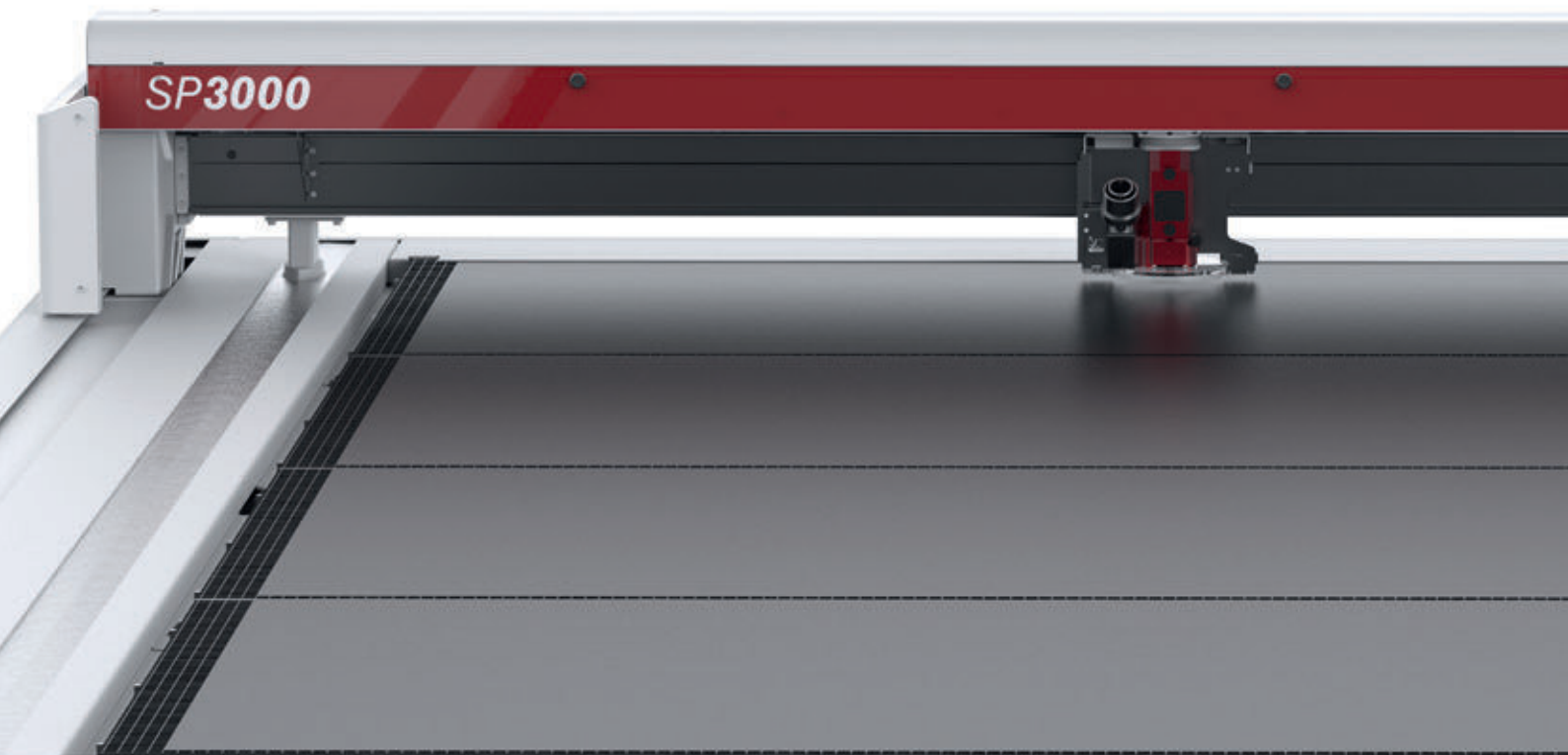

# **trotec**

*laser. marking cutting engraving*



148812

Trotec Laser GmbH  
Freilinger Strasse 100  
A-4614 Marchtrenk  
trotec@troteclaser.com  
Tel. +43 / 72 42 / 239-7777  
Fax +43 / 72 42 / 239-7380

 /TrotecLaserInc  
 /TrotecLaserEngraving

[www.troteclaser.com](http://www.troteclaser.com)  
[www.trotec-materials.com](http://www.trotec-materials.com)